

Preface

Congratulations on purchasing laser cutting and engraving machine, this device is a high-tech product of light, mechanic, and electron. This manual provides necessary information on how to use and service the machine. It instructs the installing and debugging of the machine; installing, setting, and operating of the software; daily maintains and safety attentions. Every instruction especially on the service and operating process to avoid misuses which void the warranty. Since it is impossible to describe all what can be done or not with the machine, in case that a process not described in this manual is carried out, contact service department for authorization. Thank you!

All the staff involved in setting up, servicing and using the machine must have read and be acquainted with this manual.



<http://www.mayaemb.com> sales@mayaemb.com

V1.0 January 2008

Safety Affairs

- ★ Before using this machine, users must read this instruction and some correlative manual books and comply with operational rules strictly.
- ★ Laser machine exist hazard. Users must think carefully about whether object is suitable to be process.
- ★ Machining objects and letting objects must accord to local laws and statutes.
- ★ This device use class 4 laser equipment (strong laser radiate), and the following affairs must be regarded: A, avoiding igniting the tinder around; B, during the process of machining, some toxic or baneful gases may be produced by different machining materials; C, direct irradiating of laser may cause hurts to human body. So hydrant instruments are required in machine's using place, flammability and explosive objects are forbidden to stock near the machine, at the same time a good ventilated place is needed.
- ★ The device must be placed in a draught environment far from pollution, shake, strong electricity and strong magnetic filed. Working temperature of environment is about 10-35 centigrade and working humidity of environment is 5-95% (no coagulate water).
- ★ Working voltage of the device: AC220V, 50Hz. When voltage is not steady or frequency is not compatible, it is not allowed to turn on the machine.
- ★ Cutting machine and its correlative devices must be grounded safely before you turn on the machine.
- ★ When machine is working, operator must pay attention to working condition, turn off power when abnormal conditions happen and adopt responsible methods.
- ★ Irrelative holophotes and diffuse reflection objects are forbidden to put in device in order to prevent laser from being reflected to human body and flammable objects.
- ★ Device must be far away from electrical instrument that is sensitive to electromagnetic disruption, for this device might produce electromagnetic disruption to it.
- ★ High voltage and some other potential dangers exist in interior of the device, non-professional staffs are forbidden to open it.

Contents

Chapter 1 Introduction	1
1.1. Appearance of machine	1
1.2. Checking supplied accessories	2
1.3. General features.....	2
1.4. Technical parameters.....	3
1.5. Hardware requirements for computer.....	4
Chapter 2 How to install	5
2.1. Fix the laser	5
2.2. Exterior connection	7
2.3. Cooling water system.....	7
2.4. Dust removal and air exhaust system	7
2.4.1. Connect air pump	7
2.4.2. Air exhaust system	7
2.5. Adjust optical path	8
2.5.1. Ascertain the position of incident point.....	8
2.5.2. Adjusting principle	9
2.5.3. Adjusting method	10
2.6. Adjust focus.....	14
2.6.1. Simple way to adjusting focus.....	14
2.6.2. Complicated way to adjusting focus.....	15
2.7. Adjust the current	16
Chapter 3 Start up and get work.....	17
3.1. Request for environment	17
3.2. Usage of control panel.....	17
3.3. Work flow.....	20
Chapter 4 Getting to know your machine	22
4.1. Laser system.....	22
4.1.1. Laser	22
4.1.2. Laser path system	22

4.1.3.	Laser power supply	22
4.2.	Control system	22
4.2.1.	Motherboard	22
4.2.2.	Main board.....	22
4.2.3.	Control panel	22
4.3.	Work area.....	23
4.4.	Dust removal and ventilation system.....	23
Chapter 5	Something for attention and maintenance.....	24
5.1.	Attention and maintenance	24
5.2.	Trouble shooting	26
Appendix A:	Fast start guide	28
Appendix B:	Control panel for machine of two laser heads	30

Chapter 1 Introduction

1.1. Appearance of machine

Appearance of the machine shown in Pic.1-1, Pic.1-2:

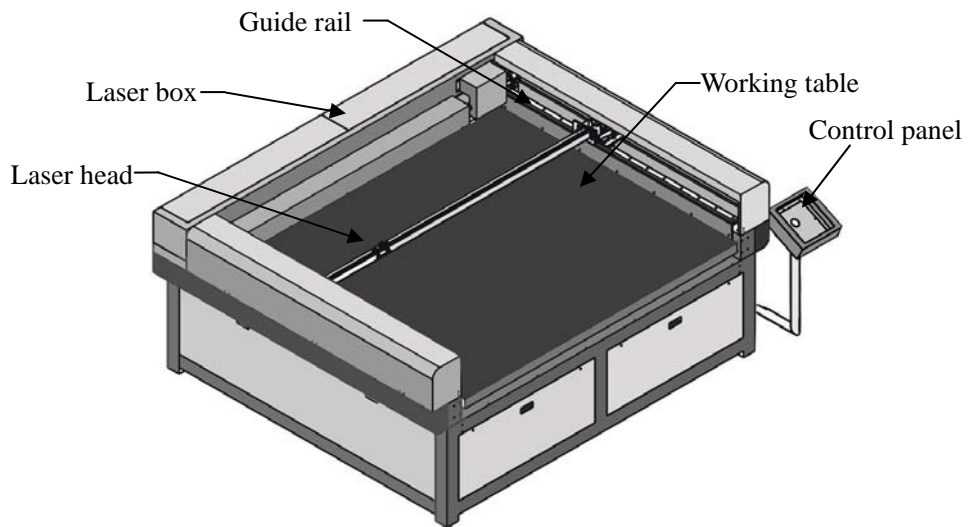

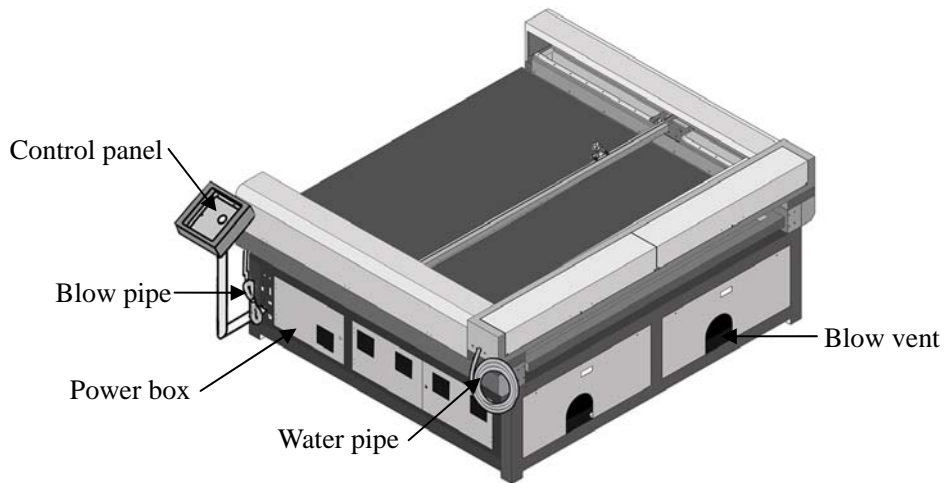

Pic.1-1 Left side of the machine



Pic.1-2 Right side of the machine

1.2. Checking supplied accessories

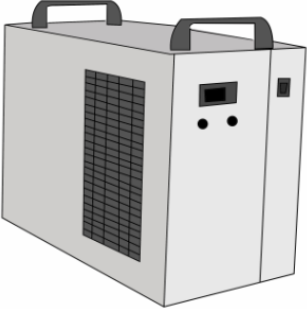
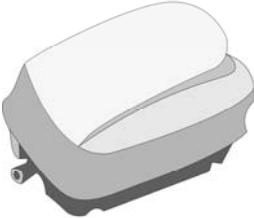
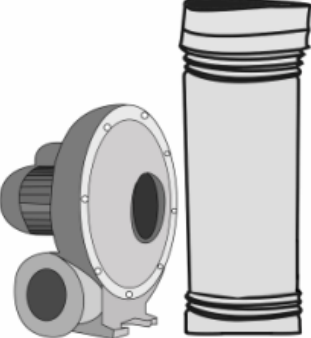
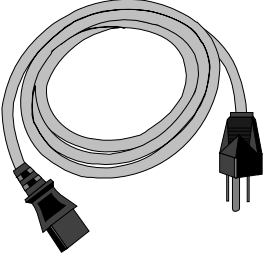
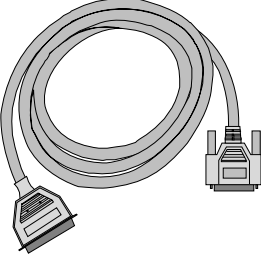
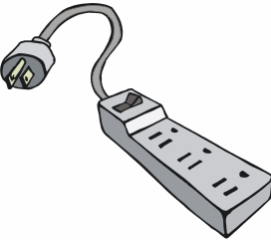
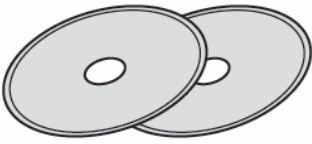
Besides mainframe of the laser cutting machine, your accessories may include following
(The following may not agree with practical object, according to the practical object):

<p>Water cooler</p> 	<p>Air pump</p> 	<p>Centrifugal fan, air pipe</p> 
<p>Power cable</p> 	<p>Data line</p> 	<p>Electrical outlet</p> 
<p>ACE software</p> 	<p>USB dog</p> 	<p>Focus tool</p> 

1.3. General features

The FLC series laser cutting machine includes FLC1613, FLC1813. They have the following characteristics:

- **Three processing methods**

This machine has three processing methods: cutting, engraving and scan. Cutting processes

the pattern along its outline. This machine can cut the work piece to different depth according to the color. Engraving and scan means scan the lattice pattern line by line. The scan can make the half-tone pattern.

- **Suitable for many nonmetallic materials**

Such as wood、 bamboo, organic glass, rubber, leather, cloth, textile and their sheets.

- **Excellent processing quantity**

This machine's precision is 0.025 mm, it can process the work piece with high precision, smooth curve outline and accurate lattice.

- **Easy to operate**

We provide double English software: ACE and PRINTER DRIVER, they are easy to learn, and developed by ourselves. It's convenient to operate the machine as it is controlled by the computer.

- **Skillful construction**

You can choose different worktable according to your need such as honey comb table, aluminum or plat table.

- **Neat working environment**

The working process is clean, quiet with least waste of material.

1.4. Technical parameters

Model	FLC1613	FLC1813
Working area (mm)	1600×1300	1800×1300
Table size (mm)	1750×1800	1950×1800
Volume (mm)	2200×1800×1150	2400×1800×1150
Function	Cut /Engrave/ Scan	
Cutting speed (cm/min)	≅ 3800	
Resolution ratio	1000dpi	
Laser (W)	Glass tube 60/80W, RF laser30/55/100/200W	
Gross power	Between 600~1500W	
Net weight (kg)	200	220

PS: Working area means the largest picture the machine can finish in cutting function; the working area is smaller in engraving and scanning function.

1.5. Hardware requirements for computer

CPU: An Intel Pentium 500 or above.

Memory: 256MB or above.

Hard disk: 1GB or above.

A color monitor: 600*800 resolution, 16 colors or above.

Others: CD-ROM drive, parallel interface and USB.

Operating system: Window95/98/ME, Windows2000/NT/XP.

Chapter 2 How to install

2.1. Fix the laser

The laser tube doesn't fix on the machine, so you must fix it before using.

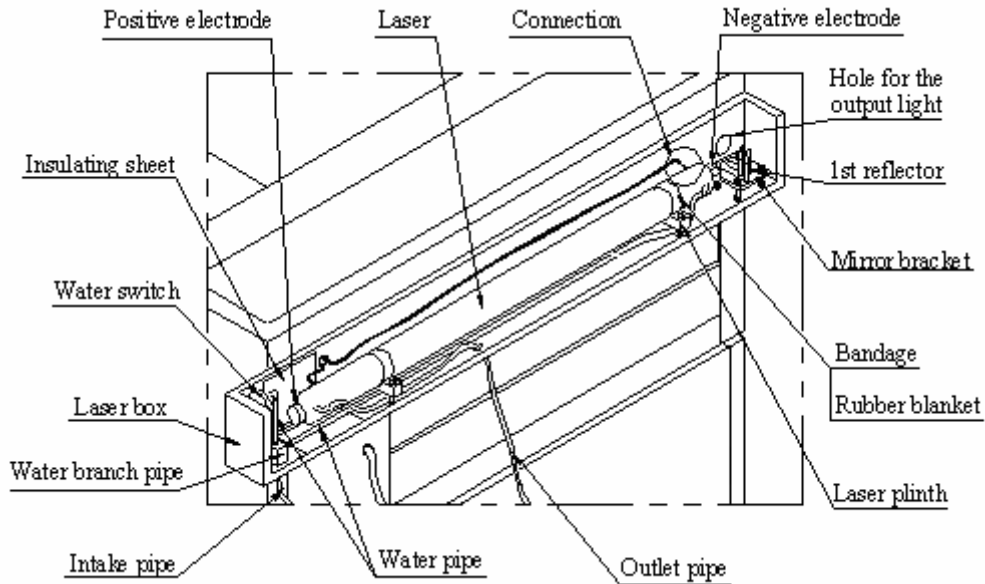

Pic.2-1 Laser system

Step1: Open the laser box and take out the laser tube.

The side emission of light is cathode, have a hole. The other side is anode and the helix trachea of the laser is in this side. As shown in pic.2-2.

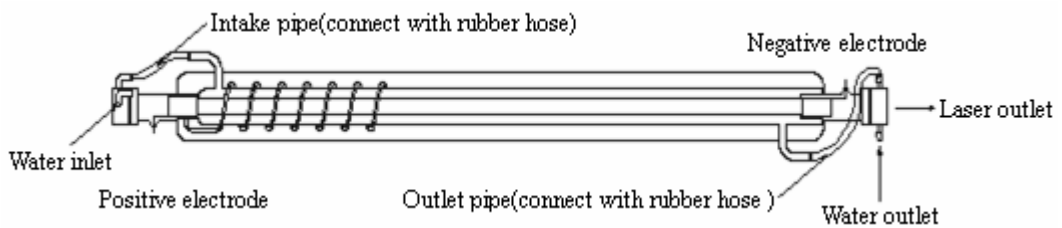

Pic.2-2 Glass laser tube

Step2: Fix the laser tube as shown in pic.2-3.

- (a) Fix one side of the bandage on the laser plinth with M4 wrench. (Attention: don't fix so tight).
- (b) Use the gluey paper to wrapping the rubber blanket on the laser.
- (c) Put the laser where wrapping the rubber blanket on the laser plinth.
- (d) Tight the screws on both side of the bandage, fix the laser on the laser plinth.
(Attention: the laser can not glide and the bandage should be contacted to gasket after tight, don't fix the laser so tight, because it is easy to break down)

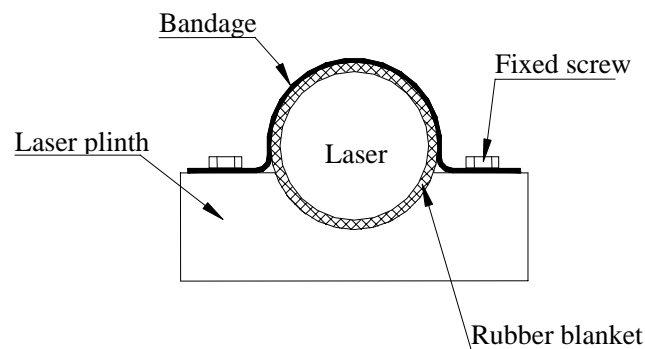

Pic.2-3 Fix the laser tube

Step3: Connect the red high voltage line with the anode of the laser, and connect the yellow wire with the cathode of the laser. As pic.2-4 shown:

- (a) Enwind the wire around the electrode
- (b) Submerge all of electric parts which are exposed with 703 insulation cement.
- (c) Put the insulating cover on the electrode.

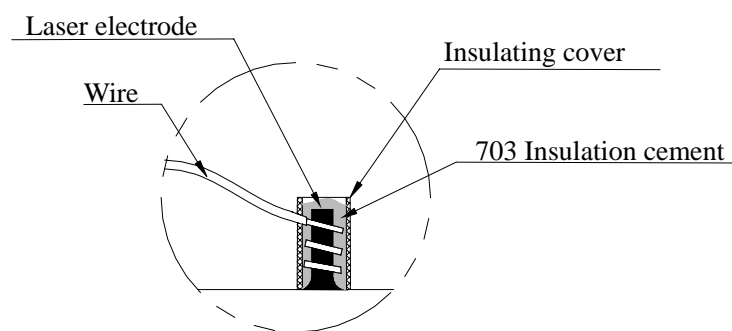

Pic.2-4 high voltage treatment

Step4: Connect the intake and outlet water pipes to the laser tube. As shown in pic.2-2.

2.2. Exterior connection

Connect all the lines with the corresponding port on the machine. There are two ports in the right side of the power box (shown as pic 1-1), one is for data line, and the other is for supply power line.

Step1: Connect the data interface with the computer by the data line.

Step2: Connect the power port to 220V/50Hz AC electrical source by power cable.

Attention: Don't turn on the power before the cooling water work well.

2.3. Cooling water system

The black water pipes are connected at the left side of the machine (water pipes of machine with two laser heads are connected at the right side of the machine). Connect the intake and outlet water pipe to the right ports of the water cooler. Make sure that the cooling water is clean and cold, and it is flowing well in the glass laser tube before every time you using the machine.

2.4. Dust removal and air exhaust system

2.4.1. Connect air pump

Connect the white blowpipe at the side of the machine (Pic.1-1) to the air pump, after turn on the air pump power supply, the blowpipe besides the laser head gets start.

The processing quality is guaranteed by using the air pump; it not only can blow away the waste, but also cool off the workpiece surface quickly.

2.4.2. Air exhaust system

You can see several blow vent at the back of your machine (Pic.1-1), connect the centrifugal fan and the blow vent with the pipes.

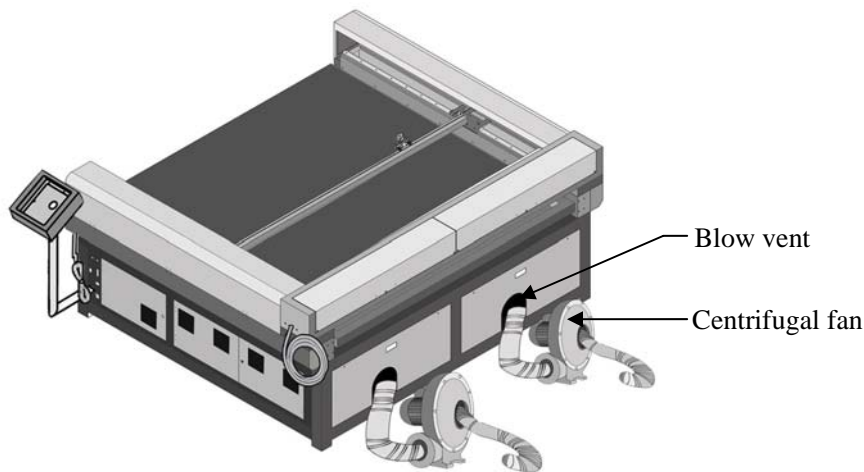

Pic2-5 Air exhaust system

2.5. Adjust optical path

If the reflection path of the laser offset the right way, please adjust it as soon as possible. The incident ray must shoot at the centre of each mirror. Before you adjust the path, you must attend to the following things:

- The laser light is invisible light, and it is very dangerous. You must avoid the laser shooting on your body.
- Keep on the cooling water circulating inside the glass laser tube before adjusting optical path. Prevent the glass laser tube from working without the cooling water.

2.5.1. Ascertain the position of incident point

Ascertain the position of incident point before adjusting the optical path, the steps are as follows:

- (a) Select the optical path is open. The laser beam can penetrate a Mylar in 2 seconds.
- (b) Put a piece of Mylar in front of the reflectors (attention: the Mylar and the reflector are not too close, in case of pollution the reflector when the beam is shooting on the Mylar).
- (c) Turn on the “Light” Key and turn it off quickly. Then the laser beam burn through the Mylar. The hole burnt by the laser beam is corresponding the incident point on the

reflector (sometimes there are two holes on the Mylar, the small one is burnt by the reflected beam from the mirror, so you can find tend towards of the optical path from the angle which produced by the incident point and the reflect point)

Attention: because the optical path is too long, you should find the laser beam from near to far.

Before adjusting the optical path, you also need to adjust the height of the 1st mirror bridge and laser plinth, to make sure that the incident point of the laser, the center of the 1st reflector and the center of the 2nd reflector are at the same height. The laser beam must through the hole on the side of the laser box.

2.5.2. Adjusting principle

Adjusting the optical path mostly relies on changing angle of the reflector. There are three screws on back of the reflector’s shelf, the flex of the screw determine the angle of the mirror, as the pic.2-6,2-7shown.

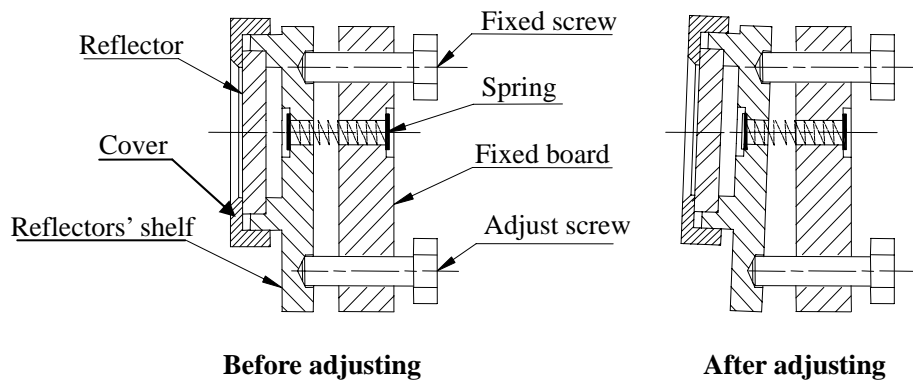

Pic.2-6 1st and 2nd reflector shelves

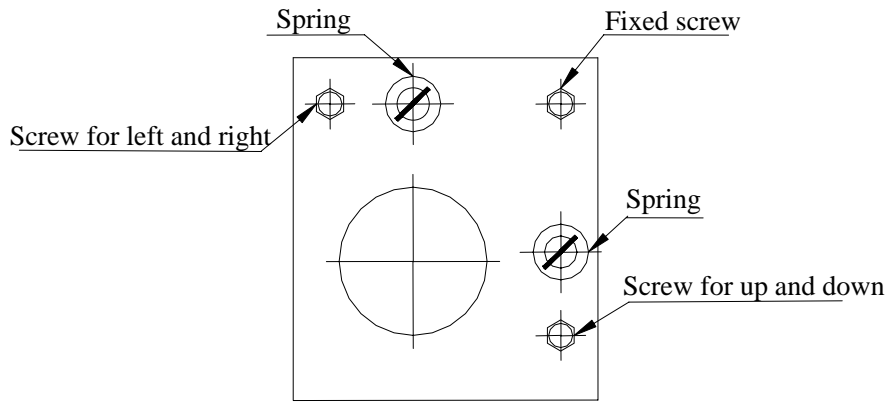

Pic.2-7 Adjust screw of the reflectors' shelf

Adjust the screw for left and right to make the incident point move left or right at the next reflector. It is the same principle to adjust the up or down position of the incident point by the screw for up and down. Adjusting the fixed screw, the incident point moves along the oblique line at the next reflector.

The work area of the machine is very large and there is long distance between the two reflectors. So you should snail the screws of the reflectors when adjusting the optical path.

2.5.3. Adjusting method

The optical path and the configuration of the laser head are as the following pic2-8 and pic.2-9 shown:

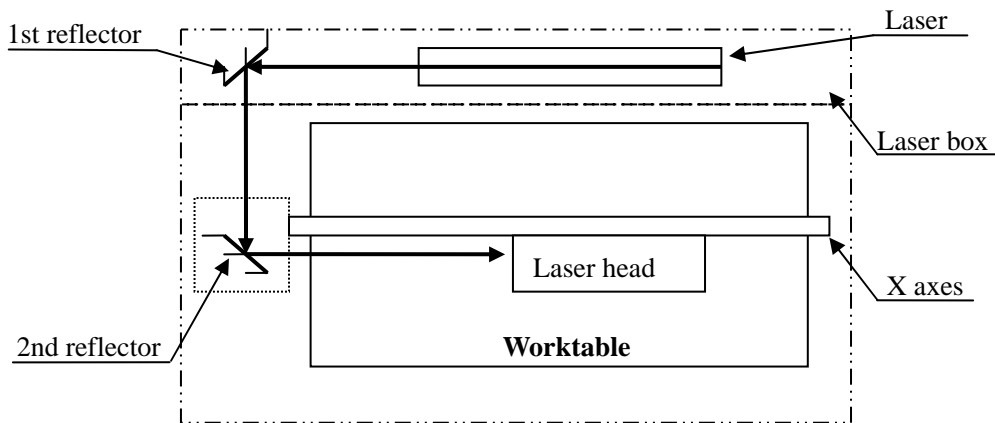

Pic.2-8 Optical path

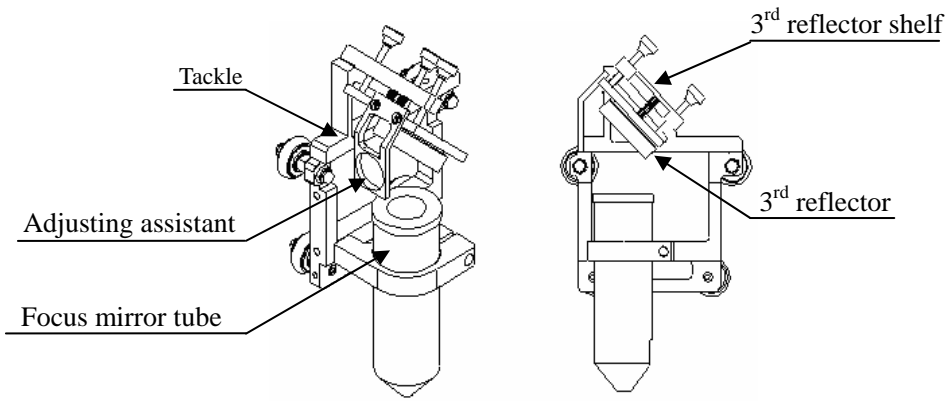

Pic.2-9 Laser head configuration

First adjust each reflector roughly, make it perpendicular to the plane location, and maintain the angle of 45° with X direction. At this time, the three screws between the reflectors' shelf and the fixed board should have same length.

Step1: Ensure that the laser beam hits the center of the 1st reflector.

Step2: Paste a piece of sticky tape before the 2# mirror or other material on which the laser can make a mark. Move the crossbeam (X direction guide rail) to the nearest point to the laser tube and then press the "light" button to make a mark on the tape. (Attention: in order to avoid hurts, please use a piece of pasteboard to locate the laser, then adjusts the light path.).

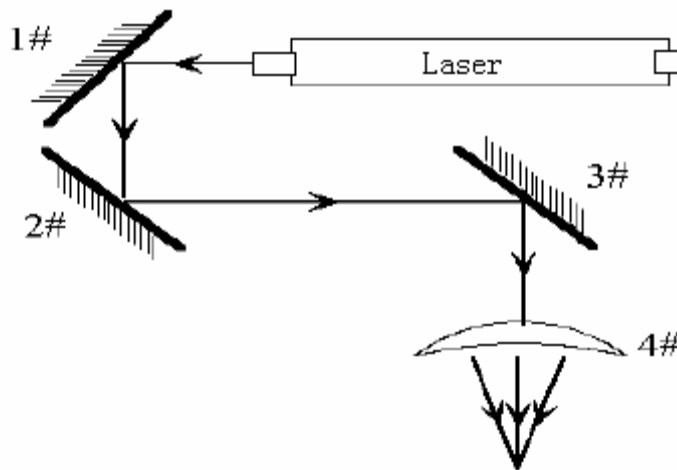

Step3: Move the crossbeam away from laser tube gradually and press pulse to make a mark.

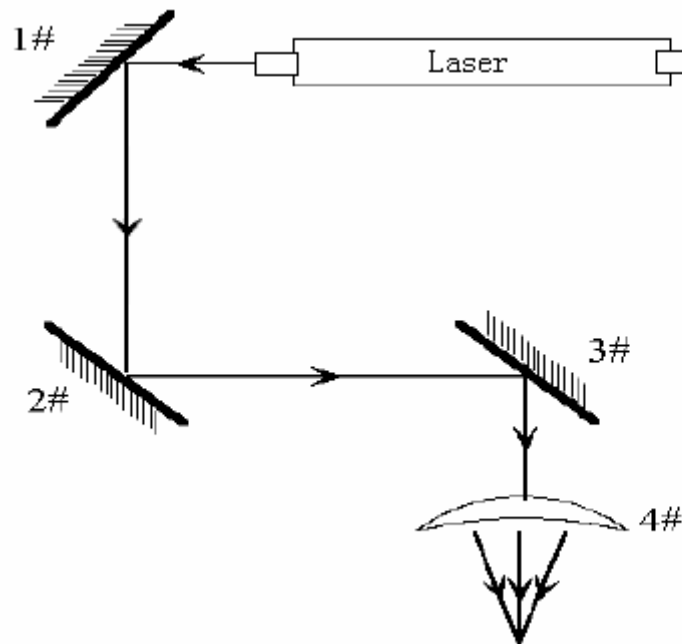

Step4: If the two marks do not at the same point on the tape, you can adjust 1# mirror and make the two marks overlap at the same point.

Step5: Redo step 2 to step 4 till the two marks overlap at the same point.

Step6: Paste a piece of sticky tape before the 3# mirror or other material on which laser can make a mark. Move the laser head to the nearest point to the laser tube, the press the pulse button to make a mark on the tape.

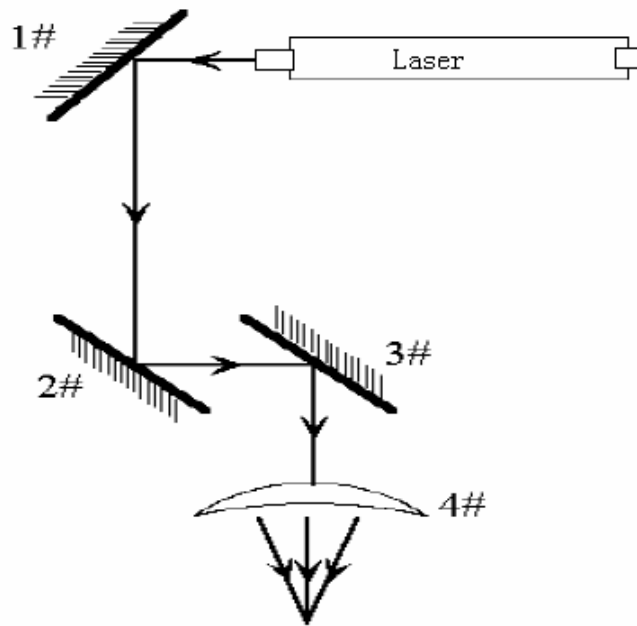

Step7: Move the laser head away from mirror 2# gradually and press pulse, make a mark.

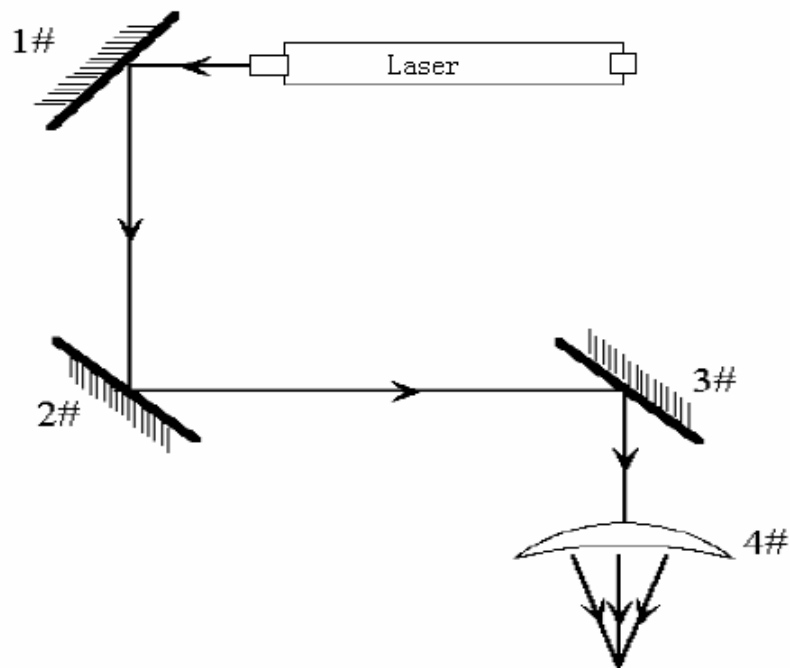

Step8: If the two marks do not at the same point on the tape, you can adjust 2#mirror and make the two marks overlap at the same point.

Step 9: Redo step 6 to step 8 till the two marks overlap at the same point.

Step 10: Paste a piece of tape before 3# mirror. Press the pulse button to make a mark on the tape. If the point is in the center of the hole, we can finish it here now.

Step 11: Additional adjustments are needed if the laser mark is not in the center of the hole, such as figure below:

In this example, the point moves outside and above a little.

Up-down error: raise or lower the laser tube.

In-out (left-right) error: adjust laser tube front to back.

In this example, we must lower the laser tube, and then redo the adjustments starting from the first step.

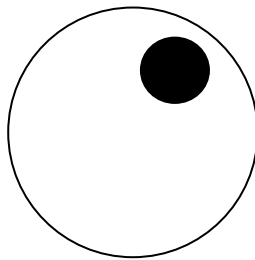

Note: All the adjustments must be done by professional personnel as the laser beam is inherently dangerous to skin and eyes.

2.6. Adjust focus

The valid carving needs the laser light point small, the power concentration, only have these two conditions, then can promise the accuracy and the depth of carving. When the laser beam just projected from the laser machine, diameter about 3 millimeter, the power density was lower, can't carve, through the mirror focus, the focus light beam was thinner, diameter is about 0.1. It is the best position of the carving. Therefore, fix the waiting engraves flat at the focus of mirror's focus place is the condition of successful carving.

2.6.1. Simple way to adjusting focus

Such as figure 2-10 show, the focus mirror install in the focus mirror tube, after loosen the pen type laser head clip's lock tight bolt, the focus mirror tube can move up and down in the pen type laser head clip. Underneath 8 mms of the mirror tube is the focus place flat

surfaces. The C series laser cutting machine's accessories include a piece of 8 mms thick organic glass of focus block, using to make certain of the focus surface.

While regulating the focal distance, put the process material on the work stage, and then put the focus block on the waiting process material surface. Loosen the lock tight bolt of the open type laser head clip at first, move the focus mirror tube up and down, make the focuses mirror tube's nether surface stick to the glass block, then the waiting process material locate the focus surface. Regulate focus height according to the demand, and then put the lock tight bolt tight.

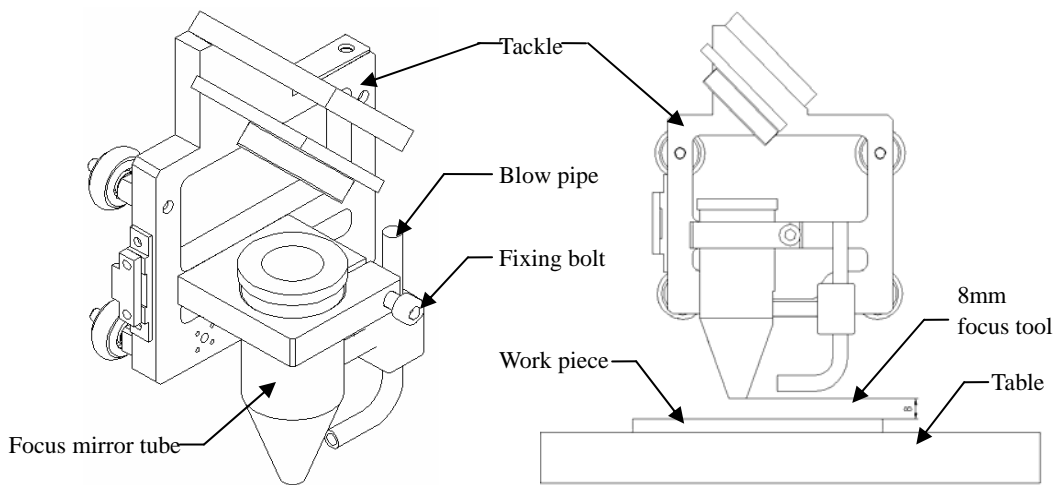

Pic. 2-10 Adjusting focus

2.6.2. Complicated way to adjusting focus

Focus distance is decided by the focus mirror, different focus mirror will have deviation slightly, should notice to regulate while replace, the concrete method is as follows:

Step1: Press "the high pressure switch", press again "light on", and regulate the laser exportation electric current size about 5 mill-Ampere, raise "light on".

Step2: Seek focus point.

- 1) Put organic glass inclination on the work stage, the declining angle of the side and the work space is about 50-60 degrees.
- 2) Use the ambulation button of the control panel, move the focus mirror to the

organic glass suitable position.

3) Press "light on" in the meantime, let the focus mirror follow X move, make the laser row lengthways in the top of the transparent and draw a two head thick and the center thin line on the organic glass net . Raise light on" immediately .The on-line most thin place is the focus.

Step3: Measuring the transparent and organic glass's finest place to the focus mirror tube descend surface distance, the distance can be considered as the focus mirror focus height's reference value while adjusting the focus.

2.7. Adjust the current

First make sure there is cooling water flows in the laser. Then you can turn on the power switch on the machine. Turn on the "H. V." and "Light". At this time, the laser has output. Regulate the knob on the control board to adjust the current. Then turn off the "Light".

Attention: The laser beam is invisible. You can put a mylar film into the light path to judge the situation of the laser output. Avoid the laser shooting on any parts of your body.

Chapter 3 Start up and get work

3.1. Request for environment

- Voltage

Exterior voltage is used 220V/50Hz. The voltage is too high or too low will affect the machine work, disturb the data, let the power instability and shorten the life of the laser. If there being a problem with the power supply, you should set a regulator.

- Temperature

Keep the environment temperature at 10-35°C to make sure the circulate water work well. If the environment temperature is too high or the machine has worked a long time, you should observe the temperature of the water, and you should increase the quantity of the water and change the water frequently.

- Humidity

Inside of the machine have a high voltage, humidity will strike fire, and it is dangerous. Put the machine at a dry environment, and keep the inside of the machine dry. Besides, too dry environment and air-condition accumulate static on the surface of the machine easily, will disturb the data, so you should keep the ground work well.

- Cooling water

It is important to setting cooling water. If the tap water is too hard, you should use purify water, and keep the cooling water clean.

- Cleanness

Process plastic and leather will produce mordant substance. It will destroy the mirror and circuit board. Please clean the machine after working every day. Make sure the ventilation and dust removal systems are work well, unpick and wash the vent-pipe and the exhaust-fan regularly.

3.2. Usage of control panel

The control panel takes charge of adjust current, control the move of X-coordinate and Y-coordinate in manual.

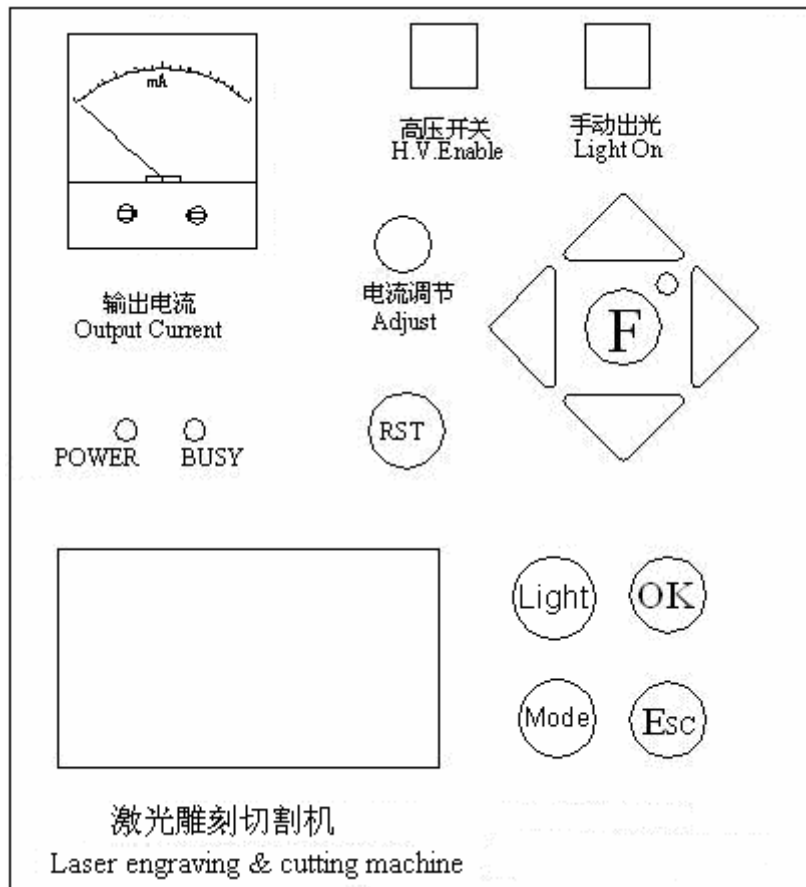

Various functions of the control panel are as follow:

The ampere meter (“Output Current”): When you press the “H. V. Enable” and “Light out” key at same time, you will see the current showing on the ampere meter. It’s the output current of the laser.

Key “H.V. Enable”: High voltage switch. Only after this button is pressed, the laser can have the output.

Key “Light On”: Out the light by hand. Press this button after you press the “H. V. Enable”, the laser out of light continuously.

Key “Adjust”: Regulate this knob to adjust the output current.

Key “RST”: flexible reset button. Press this key, the laser head restart check; go back to the top right corner of the worktable, complete reset.

Shift keys of the laser head: It composes with up, down, left and right movement keys. Under the offline working pattern (the computer does not transmit the data to the machine), press any one of these keys, the laser head will move compliance with the arrowhead’s

indication.

Key “F”: Orientation key, press this key, the coordinate where the tackle located in was supposed as an origin point.

Key “light”: In test mode, press this button, the laser tab will generate light.

Key “mode”: Change the working mode of the machine.

Key “OK”: Change the condition of the optical path, enter into further menu and affirm save the change.

Key “Esc”: quit currently menu, return to the previous menu and cancel the change of the file which already saved.

LCD screen: After check of boot-strap, the display shows as follows:

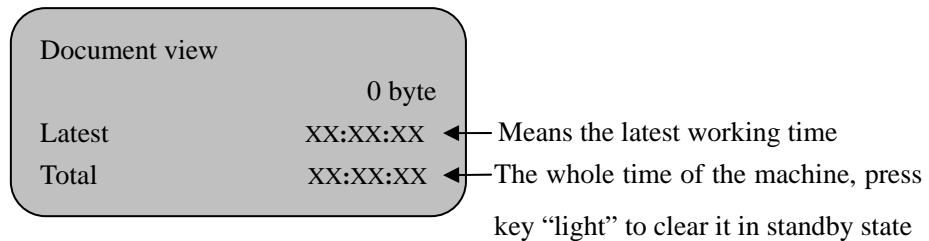

Use the key “Mode” to change to the optical path adjustment status, the display shows:

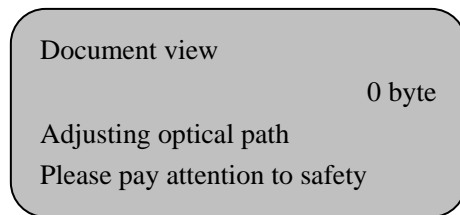

At this time, press the key “light”, the laser beam emission by manual, adjustable optical path and focus.

When output data and the machine working, the display shows:

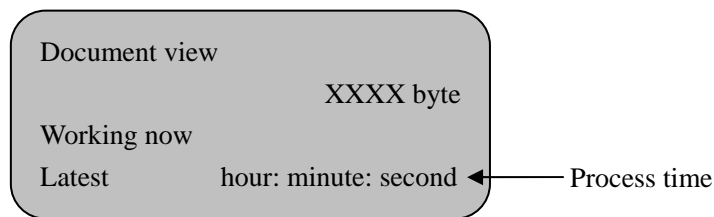

At this time, the red light over the BUSY shine, open the up cover of the machine, the buzzer sound and the red light shine.

3.3. Work flow

- **Step1: Installing of the machine**

Complete the installation of the laser system, cooling water system, dust removal and air exhaust system (method details in 2.1,2.3,2.4).

Attention: Don't turn on the power before the cooling water work well.

- **Step2: Connect exterior lines** (method details in 2.2)

Connect the power cable on the machine, and connect the machine with the computer by the data line. Then turn on the power of the machine and the computer.

Attention: Keep the ground line work well.

- **Step3: Adjust optical path** (method details in 2.5)

Turn on the power of the water pump, air pump and the exhaust fan or dust clean device.

Attention: Prohibit from working without the cooling water.

- **Step4: Set up print driver, USB dog driver and ACE software.** (Details in Print driver user's manual and ACE user's manual)

- **Step5: Edit the pattern**

Enter the software to draw a pattern by yourself or import a picture from other files. Please find the operation detail from the user's manual of the software and read the "Usage announcement" in chapter five.

- **Step6: Draw position bound**

Put a paper on the worktable. Close the up cover of the engraving machine. Click  icon to draw the position bound on the paper. You can put the work piece in the position bound after setting the processing parameters.

Attention: Use smaller current at this time.

- **Step7: Set processing parameters**

The processing parameters include interval, speed and current. All the parameters can be set in the software. Please find the operation detail from the user's manual of the software. You should use the knob "Adjust" on the control board to set the output current.

- **Step8: Put the work piece on the worktable and adjust focus**

Put the work piece in the position bound on the worktable. Regulate the exhaust hood to make the surface to be engraving on the focal plane. Find the operation detail from 2.6 in

chapter two.

- **Step9: Output data to engrave**

Generate data in the software and output the data, then the machine will begin working.

Please find the operation detail from the user's manual of the software.

- **Step10: Finish the work**

The sound will remind you when the work is finished. During process, if the cooling water doesn't work, the work will stop. After the cooling water working well, the machine will begin working again.

Please clean the worktable after finishing engraving.

Chapter 4 Getting to know your machine

4.1. Laser system

4.1.1. Laser

You can choose glass tube made in China 40W\60W\80W, or radio-frequency tube imported from U.S.A25/30/50W.

4.1.2. Laser path system

Include three reflectors and a focus lens. The laser through the reflectors and focus lens, the beam can be focalizing, become usable. The 1st reflector is in the laser box. The 2nd reflector is on the X axes, can be move with X axes along Y-coordinate. The 3rd reflector and a focus lens are on the laser head.

4.1.3. Laser power supply

It is in the control box at the back of the machine. It main function is transformed the alternating current to high-handed electricity which the machine need.

4.2. Control system

4.2.1. Motherboard

Motherboard is mounted on the right of the power box. It main purpose is that drive motor, supply work current for main board and transmit work condition of the work parts to main board. So the main board can control the machine.

4.2.2. Main board

Main board is mounted next to the motherboard. It the main parts of the laser engraving, it obtain data from computer, then analyze, operation and transform the data, transmit it to the laser engraving, complete the process base on the compile content of the software.

4.2.3. Control panel

The control panel is located at the top right corner of the machine. (Method details in 3.2)

4.3. Work area

You can choose equipment such as flat working table, honeycomb working table or aluminum bar table. During processing, place the material on the table directly and adjust focus plane. When workpieces are light, curling or deformation by heated, can suppress the edge of the material by heavy, or paste on the table-board by use the double-face adhesive, or match fixture base on its own condition.

4.4. Dust removal and ventilation system

Dust removal and ventilation system include air-pump, blowpipe, exhaust-fan, vent-pipe. Not only cooling the surface of the processing material fast, but also blow out the dust and waste which produce by processing while protecting lens, assure the process quality through blow. While the laser process, many non-metallic materials will be produced pungent gas, which requires the vent-pipe connect with exhaust-fan (or air purifier) emission the gas out, in order to prevent environment pollution, the best method is matched an air purifier at the place where the gas export.

Chapter 5 **Something for attention and maintenance**

5.1. Attention and maintenance

- This device is a high-tech product of light, mechanic, and electron, in order to use safety and work well, do not open the back door of the machine and change the inner configuration without previous agreement.
- Put the machine at a flat place steady, avoid incline and crush.
- Please put the vent-pipe or exhaust-fan out of the room, and keep the room draughty.
- Keep inside of the machine clean and dry. Dust and damp can shorten the life of the machine badly. Avoid use the machine at damp environment (the relative humidity must be lower than 80%), and avoid the machine is affected with damp.
- Examine the cooling water, USB port and power cable. Do not uses the machine without cooling water, avoid burnt the machine. The cooling water must be clean. If the water is too hard, may produce scale in the laser tube or water pipe, it will affect the effect, even explode the machine. If find the scale in the laser, please add the 10% hydrochloric acid aqua into the cooling water, open the water pump about 20 minutes, after there is no scale, replace the water with the clean water.
- Exhaust and dust removal accumulate soot easily, you should clean the machine every week at least. Pull out the vent-pipe, spill the soot, and wipe up exhaust-fan with wet cloth.
- The reflectors and focus lens belong to consumable. If not timely maintenance, dust produce by engraving will accumulate, and corrupt the surface of mirrors. If the plating film of the mirrors is damaged, it can not reflective fully, but will absorb the heat generated by the laser, affecting both the engraving effect, and also lead to breakage mirror easily. The maintenance method is as follow:



图 5-1 Clean the mirror

- ☆ There is plating film on the surface of the mirrors, and it is symmetrical golden, if there has macula, please wipe the mirror lightly with cotton stick dipped pure alcohol (As the pic.7-7 shown). If the plating film is damaged, replace it timely.
- ☆ Rotate down the mirror cover, and then replace the 1st and 2nd reflectors with new ones. When you replace the 3rd reflector or focus lens, you should open the door of the tackle first. Replace the mirror with the mirror shelf, because the mirror is affix on the mirror shelf. The golden face of the reflector is working face, it should aim at the optical path; Keep convexity up when put the focus lens in the mirror tube. After replace the mirrors, you should adjust the optical path (detailed in 6.4).

Attention: the mirror is easy to be damaged, please be careful when you wipe or replace it.

- The laser is consumable, used for a period time, the internal gas will be consumed, and the power will be attenuation. If the depth of engraving is noticeably lighter at the same parameters, you can increase output current appropriate, and if after a period of time, the maximum current can not meet the needs of engrave, you should consider replacing laser.
- Engraving machine is precision instruments, it has higher requirement for optical path adjustment, if the optical path is offset, it will affect the engraving effect. If you find the

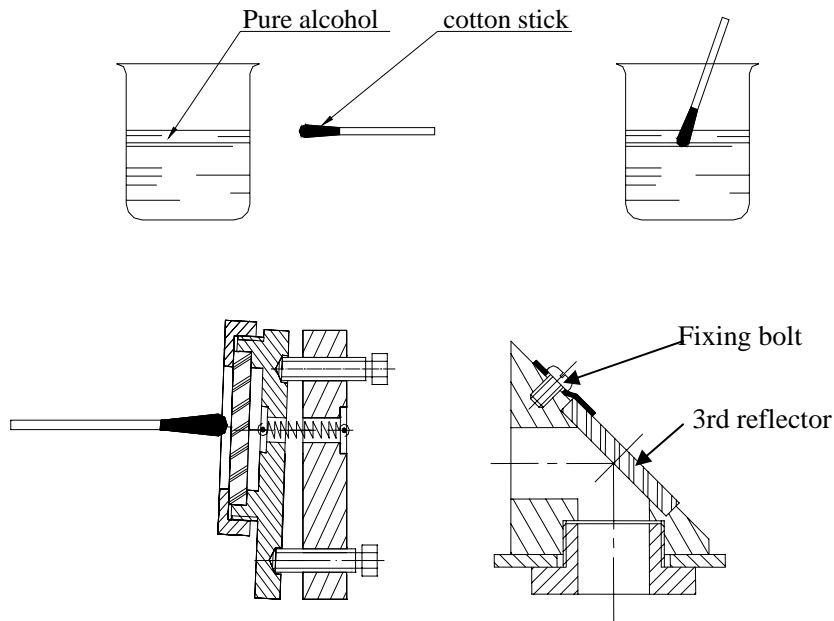
optical path is offset, you should adjust it quickly. The specific methods see 2.5.

- Processing of new materials, please judge such materials whether suitability of laser engraving, and set the parameters by experiment.
- Strictly prohibit your body into the optical path to prevent burns.
- Laser, focus lens, reflectors are consumables, not in the scope of warranty, please maintenance seriously, and if necessary change, as purchase price.

5.2. Trouble shooting

	Malfunction	Solutions
1	You can enter the software, but can't engrave	Turn off the power supply. Examine the connection of the power cable and USB cable.
2	No laser output	<p>Turn on the "H. V. Enable".</p> <p>Check whether the current and power are zero. If yes, please adjust it.</p> <p>Observe whether the temperature of the cooling water is higher, and whether the circulation of the cooling water is work well. If the cooling water is not circulation or the quantity of cooling water is small, you should turn off the power supply, and check the circulate system. The familiar situation includes the following thing:</p> <ul style="list-style-type: none"> ☆ If the water pump is not work. Check the power supply of the pump, it indicate the pump has a fault if the power supply of the pump is connected well. So you should replace it. The water pump with the machine is need: the lift is 3m above and the flow is 3000L/h above. ☆ If the water pump is work well. Check whether the outlet and intake of the laser and water pipe are open, if it is found to plug or leak, must ruled it out immediately. Clean the entry and exit points of the laser need special care to prevent damage to the glass casing. <p>Attention: turn on the water pump again only when the temperature of the laser is room temperature.</p>

		The power of the laser is attenuate, may be the life of it is ending, you should replace in time.
3	The processing effect is bad	Check whether the temperature of the cooling water is over high and whether the circulation of the cooling water is work well.
		Check whether the working face on the focal plane.
		Judge whether the power of the laser is attenuation. Please increase the current or replace a new one.
		Check whether the optical path is offset. The check and adjust methods see 2.5.
4	Draw an unnecessary line	Check the USB cable, replace new one if it necessary.
		Examine the grounding of the engraving machine and the computer. Make sure it is well.
5	Can not draw a straight line	Decrease the “cut speed” and increase the “quality” in the software.
6	Can not engrave a whole pattern	This situation may be due to typesetting had overstepped layout interface, move the graphics in the interface in editing software.

Attention: this machine is a high-tech product of light, mechanic, and electron. In order to guarantee your safety and the normal operation of machine, not to open the back cover of the machine and change the inner configuration without previous agreement. If there are some fault can not be resolved, please contact the company’s after service.

Appendix A: Fast start guide

Step1: The device must be placed far from pollution, shake, strong electricity and strong magnetic

Working humidity of environment is 5-95% (no coagulate water). Inside of the machine have a high voltage, humidity will strike fire, even make the main board and mother board burnt. So keep the inside of the machine dry.

Step2: Check working voltage

Working voltage of the device: AC220V, 50Hz; when voltage is not steady, you should set a regulator.

Step3: Install laser tube, connect cooling water system, dust removal and air exhaust system

The temperature will get higher when working, if the cooling water system doesn't work well, the laser tube will get broken. The high temperature will affect the emission of the laser tube. Don't turn on the power before the cooling water work well. If the tap water is too hard, you should use purify water, and keep the cooling water clean.

Step4: Connect power cable, data line, ground wire

Too dry environment and air-condition accumulate static on the surface of the machine easily, will disturb the data, so you should keep the ground work well.

Step5: Adjust optical path

The laser cutting machine is a high-tech product of light. The valid carving needs the laser light point small, the power concentration. Suggest you checking optical path every time before working.(Details see in 2.5)

Attention: All the adjustments must be done by professional personnel as the laser beam is inherently dangerous to skin and eyes.

Step6: Setting the print driver, driver of USB dog, ACE software

Please set this machine type be the First option. (Details see in print driver system user's manual)

Step7: Edit the pattern

Enter the software to draw a pattern by yourself or import a picture from other files. (Details see in ACE user's manual)

Step8: Draw position bound

Draw position bound before you putting on the workpiece. (Details in ACE user's manual)

Attention: Use smaller current at this time.

Step9: Set processing parameters

The processing parameters include interval, speed and current. All parameters depend on the experiments of processing material.

Step10: Put on the workpiece, and adjust focus

Adjust focus without the button "light on" press. (Details in 2.6)

Step11: Output data to engrave

Generate data in the software and output the data, then the machine will begin working. (Details in ACE user's manual)

Attention: Confirm that press button "H.V. Enable", and without the button "light on" press.

Step12: Finish the work

The sound will remind you when the work is finished. Pay attention to the cooling water system during process.

Please clean the worktable after finishing engraving.

Appendix B: Control panel for machine of two laser heads

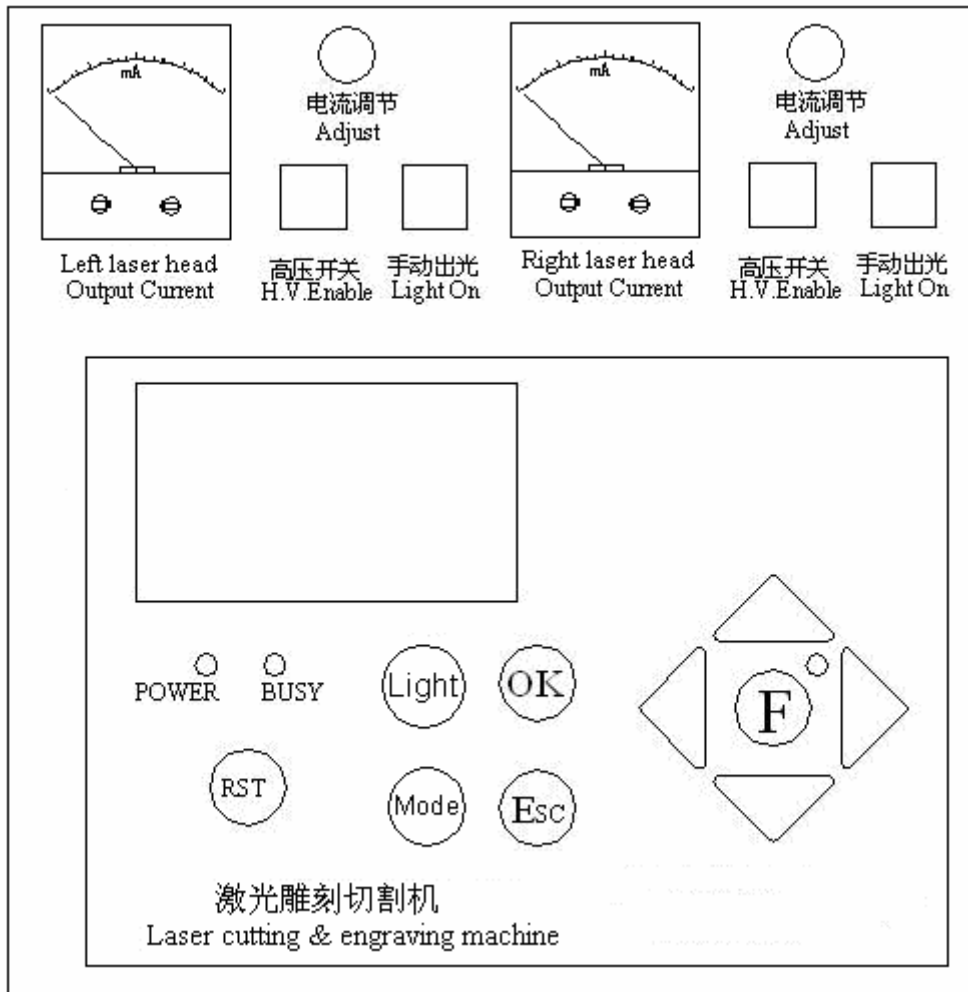

The left laser head and right laser head are control separately.

The ampere meter (“Output Current”): When you press the “H. V. Enable” and “Light out” key at same time, you will see the current showing on the ampere meter. It’s the output current of the laser.

Key “H.V. Enable”: High voltage switch. Only after this button is pressed, the laser can have the output.

Key “Light On”: Out the light by hand. Press this button after you press the “H. V. Enable”, the laser out of light continuously.

Key “Adjust”: Regulate this knob to adjust the output current.

Various functions of the control panel are as follow:

Shift keys of the laser head: It composes with up, down, left and right movement keys. Under the offline working pattern (the computer does not transmit the data to the machine), press any one of these keys, the laser head will move compliance with the arrowhead’s indication.

Key “F”: Orientation key, press this key, the coordinate where the tackle located in was supposed as an origin point.

Key “mode”: Change the working mode of the machine.

Key “light”: In test mode, press this button, the laser tab will generate light

Key “OK”: Change the condition of the optical path, enter into further menu and affirm save the change.

Key “Esc”: quit currently menu, return to the previous menu and cancel the change of the file which already saved.

Key “RST”: flexible reset button. Press this key, the laser head restart check; go back to the top right corner of the worktable, complete reset.

LCD screen: After check of boot-strap, the display shows as follows:

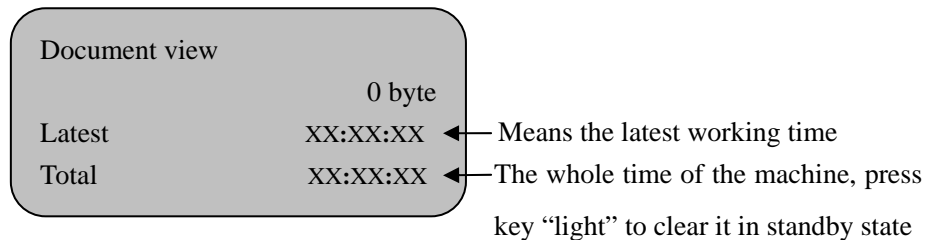

Use the key “Mode” to change to the optical path adjustment status, the display shows:

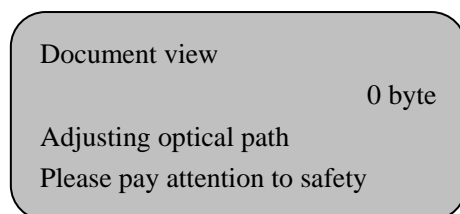

At this time, press the key “light”, the laser beam emission by manual, adjustable optical path and focus.

When output data and the machine working, the display shows:

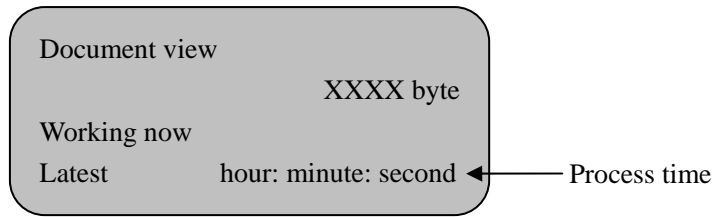

At this time, the red light over the BUSY shine, open the up cover of the machine, the buzzer sound and the red light shine.